



1

4

**Consolidating four
detectors into a
single unit cuts costs
dramatically.**

Cost reductions
Dramatically reduces costs.

Advanced pump
Features high performance pump.

Smart sensor
Equipped with smart self-diagnostic functions

Connectivity
Ethernet (PoE) support

Multi Gas Detector For Semiconductor Factories

MODEL

GD-84D-EX Series

A Gas Detector with Stunning Innovations



GD-84D-EX Series Features

Cost reductions

Dramatically reduces costs.

Advanced pump

Features high performance pump.

Smart sensor

Equipped with smart self-diagnostic functions

Connectivity

Ethernet (PoE) support

The GD-84D-EX Series is fitted with newly developed advanced next generation sensors with enhanced self-diagnostic functions. **By consolidating four gas detectors in a single unit we seek to achieve improved safety and security while reducing costs.**

Replacing four units with **one!**



Full-dot LCD for legibility! Simultaneous four-component display

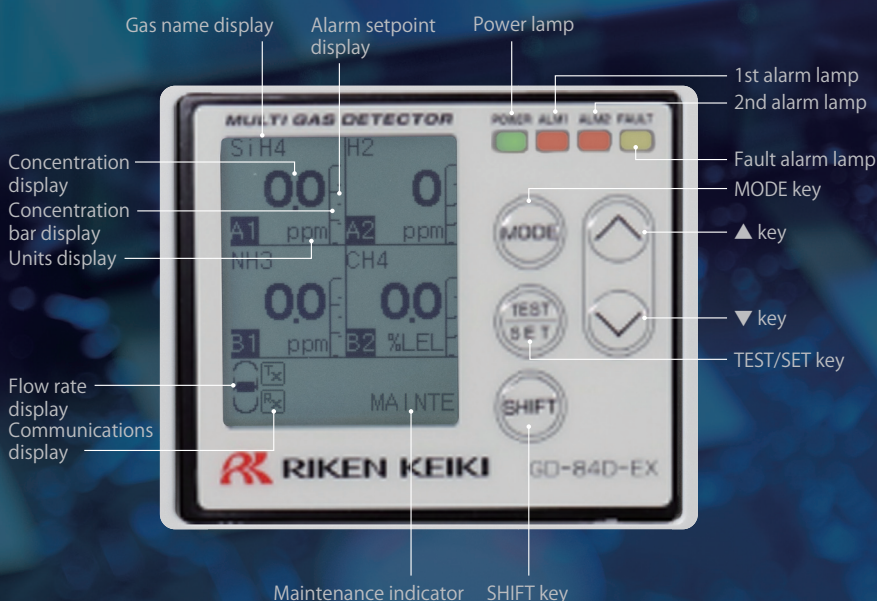

Designed for easy replacement

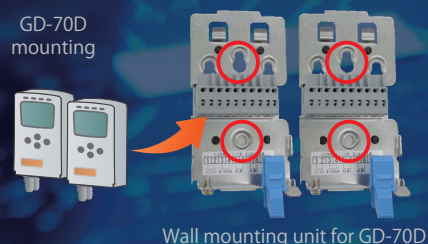

Four holes (marked red on the figure) on the GD-70D wall mounting unit allow mounting.



Cost reductions

Dramatic cost reductions compared to preceding models

● Reduced pipe installation costs

In previous models, each individual gas detector required gas inlet and outlet pipes. The GD-84D-EX reduces pipework and corresponding installation costs by up to 75 %.

* With all four sensors installed

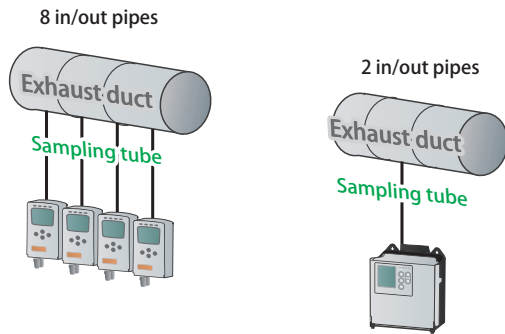

● Reduced wiring installation costs

Using the GD-84D-EX (PoE model) in conjunction with a PoE hub makes it possible to reduce both power and communication wiring installation costs and numbers of hub ports by up to 75 %.

* With all four sensors installed

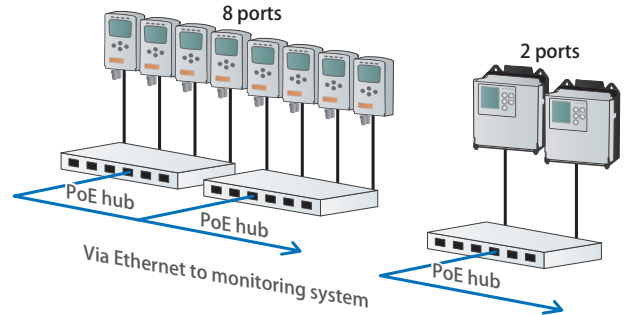

● Reduced installation space requirements

Combining the equivalent of four detectors cuts rack installation space requirements in half.

* With all four sensors installed

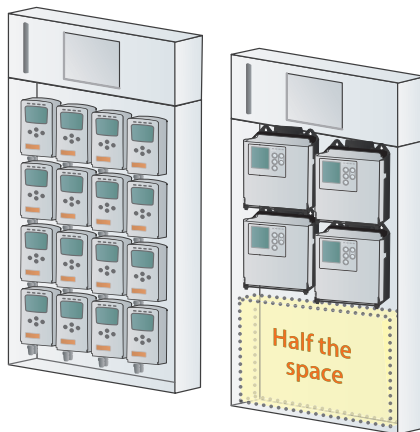

● Reduced consumables costs

Reduces replacement requirements for consumables such as pumps and dust filters by 75 %.

Also reduces replacement costs by 75 %.

Requires replacement of four sets.

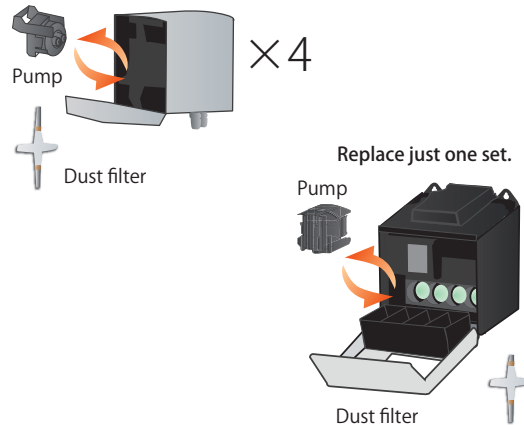

Advanced pump

Features high performance pump.



Previous model
Model: RP-70

New!

Model: RP-80

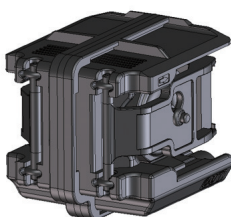

Reduced vibration

Two diaphragms to cancel vibration

Surge prevention

Buffer provided inside chamber

Smaller environmental footprint

Eliminates adhesives and bolts (and nuts) for easier recycling.

Reduced noise

Revised valve configuration

Redundancy

Twin pump → Suction possible even with one failed pump

Smart sensor

Equipped with smart self-diagnostic functions

The next generation F Series high performance sensors feature significantly improved self-diagnostic functions. (See table at right.) In addition to sensor types for the 18 different major toxic gases, the lineup includes gas sensors for 67 distinct combustible gases. Despite being 1/10 the size of previous sensors, the new sensors offer equivalent or superior interference resistance.

Self-diagnostic functions

Function	Applicable principles	Details
Service life expiration warning	All principles	An alarm is issued after three years from the start of use. * May differ depending on sensor.
Degradation diagnostic warning (sensor output abnormality)	NCF SHF SGF	An alarm is issued when the value of the drift from the initial sensor output (in air) exceeds a threshold.
Degradation diagnostic warning (fluid shortage detection)	ESF	An alarm is issued when the fluid resistance between electrodes exceeds a threshold.
Life assessment warning	All principles	An alarm is issued when the span reserve estimated based on the calibration history approaches zero.
Vitality (span reserve)	All principles	The sensor reserve is displayed when a known concentration of gas is allowed to flow.

Sensor lineup



Electrochemical type



Electrochemical type (For oxygen)



Hot-wire semiconductor type



Semiconductor type



New ceramic type

Connectivity

Ethernet (PoE) support

● Ethernet

The PoE HUB allows power supply via LAN cable, significantly reducing installation costs. It also allows operators to view the operational status of the detector via a web browser.

[User mode]

Enables checking/review of basic information such as gas names and alarm setpoints, as well as alarm history and communication history.

[Administrator mode]

Apart from check basic data, you can also change settings for alarm setpoint values or the network, run calibrations, alarm tests and fault alarm tests, reset alarms, and set INHIBIT.

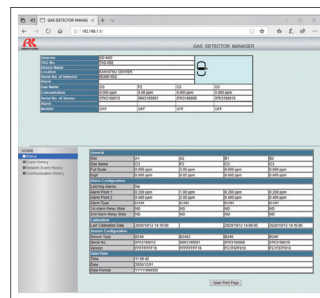

GD-84D-EX (Ethernet model)



Switching hub (PoE)



Ethernet cable

● Analog 4 - 20 mA DC

Gas concentration data is output via a general instrumentation signal (4 - 20 mA DC). This allows greater flexibility in system configuration.

Pattern 1



Indicator/
alarm unit



Detector
GD-84D-EX

Pattern 2

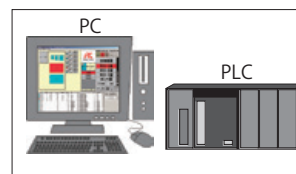

Monitoring
system



Detector
GD-84D-EX

Lineup overview

Model	Communication method	Possible sensors	Power input
GD-84D-EX-ET-EC	Ethernet only	EC only	PoE only
GD-84D-EX-ET	Ethernet only	Also compatible with sensors other than EC	PoE only
GD-84D-EX-EA-EC	Combined Ethernet/4 - 20 mA	EC only	Combined PoE/24 V DC
GD-84D-EX-EA	Combined Ethernet/4 - 20 mA	Also compatible with sensors other than EC	Combined PoE/24 V DC
GD-84D-EX-EC	4 - 20 mA only	EC only	24 V DC
GD-84D-EX	4 - 20 mA only	Also compatible with sensors other than EC	24 V DC

Lineup of main gases

[Detection principle: electrochemical type (ESF)]



No.	Sensor model	Gas name	Display name	Measurement range	Alarm setpoints	ACGIH Acceptable concentration
1	ESF-A24A	Nitrogen dioxide	NO ₂	0 - 15 ppm	5 ppm	0.2 ppm
2	ESF-A24E2	Hydrogen chloride	HCL	0 - 6 ppm	2 ppm	2 ppm
3	ESF-B242	Ammonia	NH ₃	0 - 75 ppm	25 ppm	25 ppm
4	ESF-B24A	Chlorine	CL ₂	0 - 0.3 ppm	0.1 ppm	0.1 ppm
5	ESF-X24P2	Oxygen	O ₂	0 - 25 %	18 %	—
6	ESF-A24D	Phosphine	PH ₃	0 - 1 ppm	0.3 ppm	0.05 ppm
7	ESF-A24D	Silane	SiH ₄	0 - 15 ppm	5 ppm	5 ppm
8	ESF-A24D	Disilane	Si ₂ H ₆	0 - 15 ppm	5 ppm	—
9	ESF-A24D	Sulfur dioxide	SO ₂	0 - 6 ppm	2 ppm	0.25 ppm
10	ESF-A24D2	Nitrogen monoxide	NO	0 - 100 ppm	25 ppm	25 ppm
11	ESF-A24E2	Hydrogen bromide	HBr	0 - 6 ppm	2 ppm	2 ppm
12	ESF-B241	Diethylamine	DEA	0 - 15 ppm	5 ppm	5 ppm
13	ESF-B241	Dimethylamine	DMA	0 - 15 ppm	5 ppm	5 ppm
14	ESF-B241	Ethylmethylamine	EMA	0 - 15 ppm	5 ppm	5 ppm
15	ESF-B248	Fluorine	F ₂	0 - 3 ppm	1 ppm	0.1 ppm
16	ESF-B248	Hydrogen fluoride	HF	0 - 1.5 ppm	0.5 ppm	0.5 ppm
17	ESF-B249	Ozone	O ₃	0 - 0.6 ppm	0.2 ppm	0.2 ppm (<2 h)
18	ESF-B24A	Chlorine trifluoride	CLF ₃	0 - 0.3 ppm	0.1 ppm	0.1 ppm

[Detection principle: hot-wire semiconductor type (SHF)]



No.	Sensor model	Gas name	Display name	Measurement range	Alarm setpoints	ACGIH Acceptable concentration
1	SHF-8601	Fluoromethane (CH ₃ F)	R-41	0 - 2,000 ppm	500 ppm 1,000 ppm	—
2	SHF-8601	Difluoromethane (CH ₂ F ₂)	R-32	0 - 2,000 ppm	500 ppm 1,000 ppm	—
3	SHF-8601	Isopropyl alcohol	IPA	0 - 2,000 ppm	500 ppm 1,000 ppm	200 ppm
4	SHF-8603	Deuterium	D ₂	0 - 2,000 ppm	500 ppm 1,000 ppm	—
5	SHF-8603	Hydrogen	H ₂	0 - 2,000 ppm	500 ppm 1,000 ppm	—

[Detection principle: semiconductor type (SGF)]



No.	Sensor model	Gas name	Display name	Measurement range	Alarm setpoints	ACGIH Acceptable concentration
1	SGF-8581	Methane	CH ₄	0 - 2,000 ppm	500 ppm 1,000 ppm	—
2	SGF-8562	Carbonyl sulfide	COS	0 - 2,000 ppm	500 ppm 1,000 ppm	5 ppm

[Detection principle: new ceramic type (NCF)]



No.	Sensor model	Gas name	Display name	Measurement range	Alarm setpoints	LEL
1	NCF-6318	Methane	CH ₄	0 - 100 %LEL	25 %LEL 50 %LEL	5.0 vol%
2	NCF-6320	Hydrogen	H ₂	0 - 100 %LEL	25 %LEL 50 %LEL	4.0 vol%
3	NCF-6319	Isopropyl alcohol	IPA	0 - 100 %LEL	25 %LEL 50 %LEL	2.0 vol%

- * Certain restrictions apply regarding sensor combinations. For more information, contact RIKEN KEIKI.
- * Refer to "TLVs and Bels 2020" for concentrations accepted by the ACGIH (American Conference of Government Industrial Hygienists).
- * For more information on other gases, contact RIKEN KEIKI.

[Combined Ethernet and 4 - 20 mA: GD-84D-EX/GD-84D-EX-EC/GD-84D-EX-EA/GD-84D-EX-EA-EC]

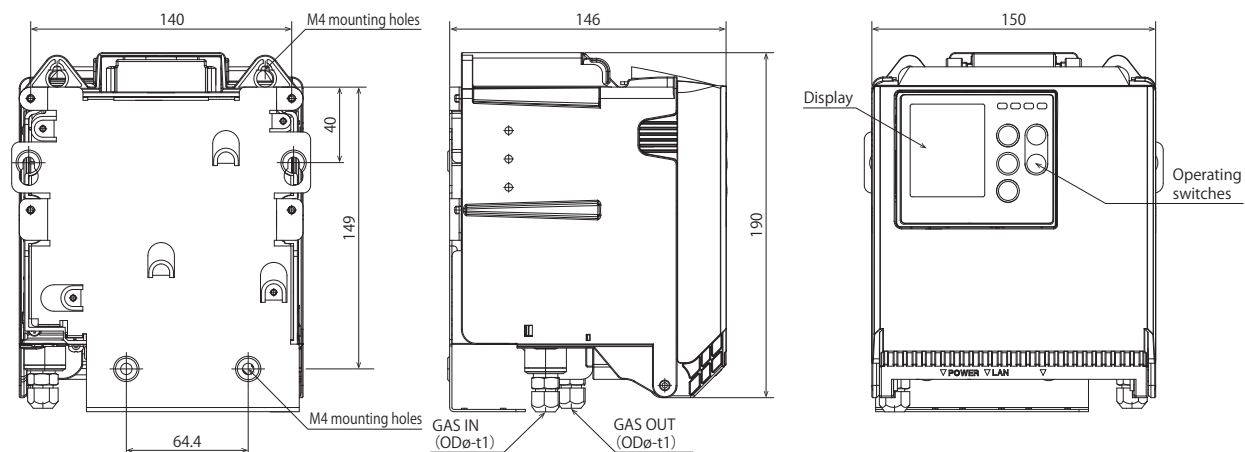

[Ethernet only: GD-84D-EX-ET/GD-84D-EX-ET-EC]

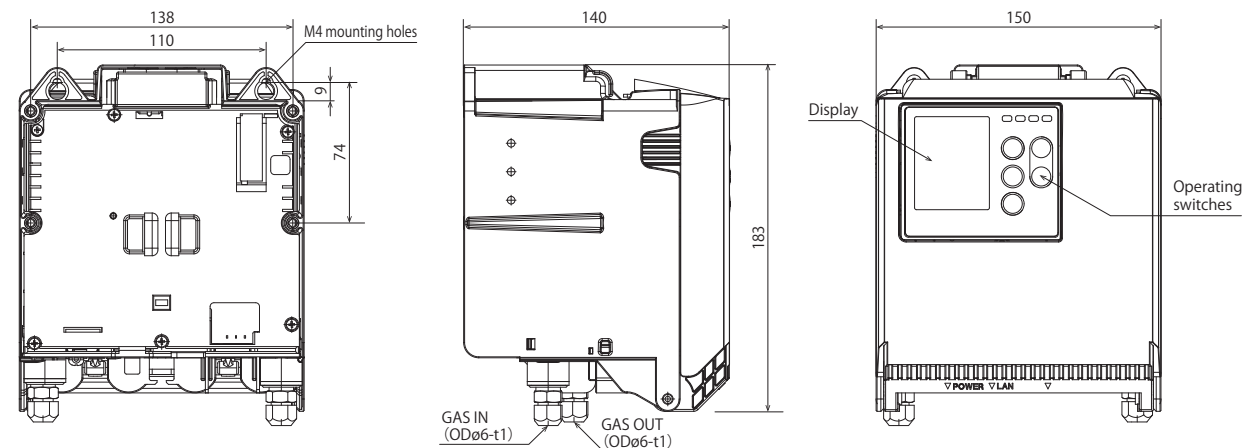

Model GD-84D-EX Specifications

Model	GD-84D-EX	GD-84D-EX-EC	GD-84D-EX-EA	GD-84D-EX-EA-EC	GD-84D-EX-ET	GD-84D-EX-ET-EC
Detection principle	Electrochemical type Semiconductor type New ceramic type Hot-wire semiconductor type	Electrochemical type	Electrochemical type Semiconductor type New ceramic type Hot-wire semiconductor type	Electrochemical type	Electrochemical type Semiconductor type New ceramic type Hot-wire semiconductor type	Electrochemical type
Detection target gas	Toxic gases, combustible gases	Toxic gases	Toxic gases, combustible gases	Toxic gases	Toxic gases, combustible gases	Toxic gases
Display	Full-dot display (gas name/flow rate/mode/communication status/gas concentration/bar meter)					
Detection method	Pump suction type					
Suction flow rate	Total flow rate: approx. 0.6 L/min					
Power supply indication	POWER lamp lit (green)					
Alarm accuracy (for identical conditions)	Within $\pm 30\%$ of alarm setpoint					
Alarm delay (for identical conditions)	* When providing gas within 60 seconds at 1.6 times the alarm setpoint (not including piping delay and communication delay)					
Gas alarm type	Two-stage alarm (H-HH, L-H, or L-LL)					
Gas alarm indication	1st: ALM1 lamp lit (red), 2nd: ALM2 lamp lit (red)					
Gas alarm pattern	Auto-reset or self-latching					
Gas alarm contact	No-voltage contact 1a or 1b, always de-energized (energized in alarm state) or always energized (de-energized in alarm state)				—	
Fault alarm/self-diagnosis	System, sensor, flow, communications, fan disconnection, or temperature increase anomaly; sensor life assessment					
Fault alarm indication	FAULT lamp lit (yellow)/detail display					
Fault alarm pattern	Auto-reset or self-latching					
Fault alarm contacts	Overall fault contacts: No-voltage contact 1a or 1b, always de-energized (energized in alarm state) or always energized (de-energized in alarm state)				—	
Contact capacity	24 V DC / 0.5 A (resistance load)					
Contact cable	CVV or equivalent cable (1.25 mm ² , up to 18 cores)					
External output	Analog transmission: 2-wire analog transmission (4 - 20 mA DC, non-insulated, resistance load 300 Ω or less, including cable resistance)		Digital transmission: Ethernet (10BASE-T/100BASE-TX) Analog transmission: 2-wire analog transmission (4 - 20 mA DC, non-insulated, resistance load 300 Ω or less, including cable resistance)		Digital transmission: Ethernet (10BASE-T/100BASE-TX)	
External output cable	Analog transmission: CVVS or equivalent shielded cable (1.25 mm ² , maximum eight cores)		Digital transmission: Cat5e or better Ethernet cable Analog transmission: CVWS or equivalent shielded cable (1.25 mm ² , maximum eight cores)		Digital transmission: Cat5e or better Ethernet cable	
Functions	White backlight, alarm delay, suppression, zero follower, sensitivity correction, flow control, calibration history, alarm trend history, event history					
Power cable	CVV or equivalent cable (1.25 mm ²) 2-core		CVV or equivalent cable (1.25 mm ²) 2-core (Shared with digital transmission cable when PoE connection is used)		Shared with digital transmission cable	
Power source	24 V $\pm 10\%$ DC		24 V $\pm 10\%$ DC or PoE+ connection		PoE+ connection	
Power consumption	When 24 V DC is connected: approx. 8 W (maximum approx. 14 W)	When 24 V DC is connected: approx. 2.5 W (maximum approx. 7 W)	When 24 V DC is connected: approx. 9 W (maximum approx. 15 W) When PoE+ is connected: approx. 11 W (maximum approx. 16 W)	When 24 V DC is connected: approx. 3 W (maximum approx. 8 W) When PoE+ is connected: approx. 4.5 W (maximum approx. 9.5 W)	When PoE+ is connected: approx. 9 W (maximum approx. 11 W)	When PoE+ is connected: approx. 3.5 W (maximum approx. 4.5 W)
Pipe connection openings	Rc1/4 (OD $\phi 6$ -1t half union for Teflon pipe (PP) supplied)					
Initialization	Approx. 25 seconds					
Operating temperature range	-10 to +40 °C (no sudden fluctuations)					
Operating humidity range	20 - 90 %RH (No condensation; may depend on the sensors installed.)					
Construction	Wall mounting type					
External dimensions	Approx. 150 mm (W) \times 190 mm (H) \times 146 mm (D) (excluding projections)				Approx. 150 mm (W) \times 183 mm (H) \times 140 mm (D) (excluding projections)	
Weight	Approximately 1.9 kg				Approximately 1.4 kg	
Exterior color	Main unit: Black/Front door: White					



RIKEN KEIKI Co., Ltd.

2-7-6 Azusawa, Itabashi-ku, Tokyo 174-8744, Japan

Phone : +81-3-3966-1113

Telefax : +81-3-3558-9110

E-mail : intdept@rikenkeiki.co.jp

Web : <https://www.rikenkeiki.co.jp/english>

★ Distributed by:

* The contents described in this catalog are subject to change without notice according to the performance improvement.